

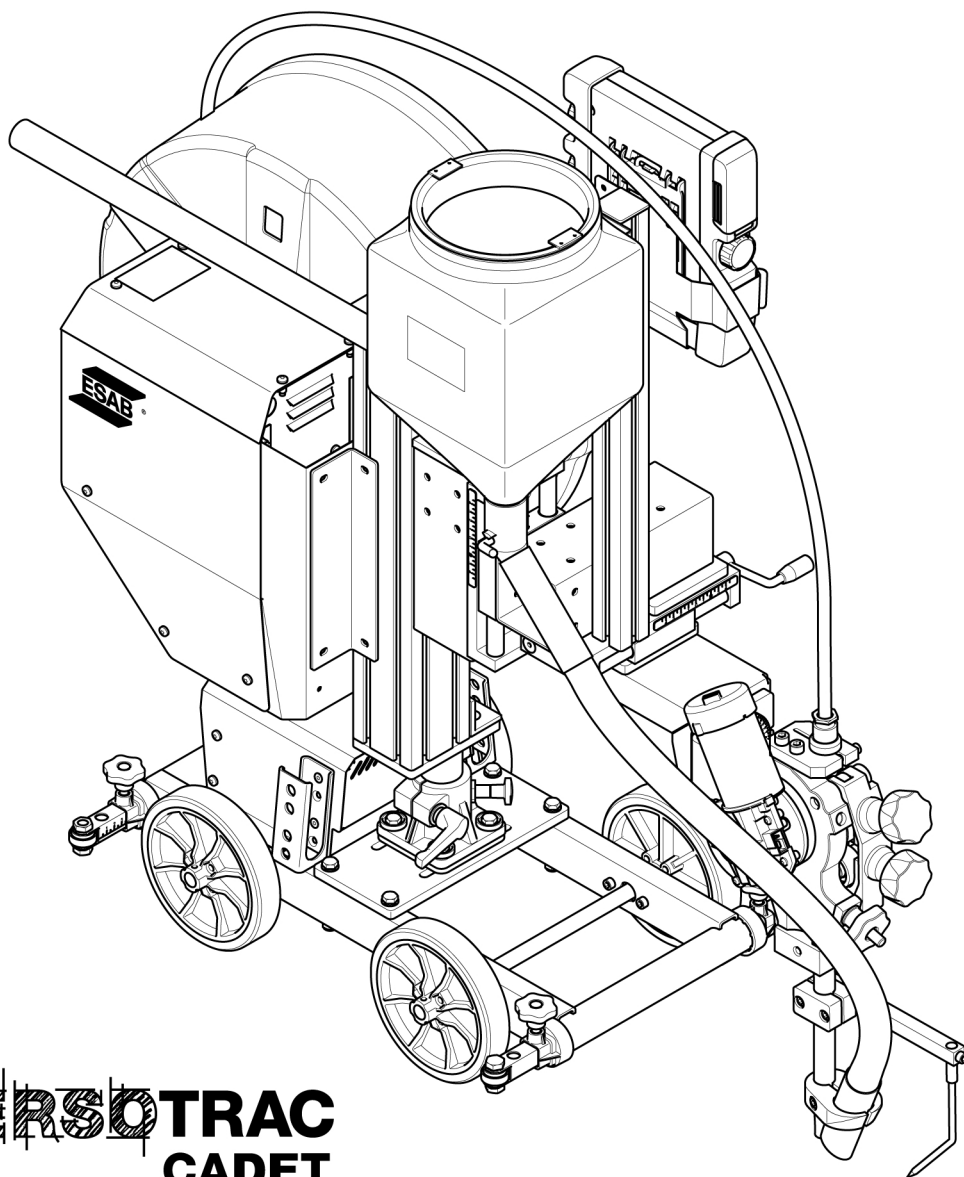

# ***Versotrac Cadet EWT 1000***

## ***SAW Tractor***



**VERSOTRAC**  
**CADET**

## **Spare parts list**

<b>Ordering no.</b>	<b>Product</b>
0910 944 880	Versotrac Cadet EWT 1000 (terminated mid 2025)
0910 944 881	Versotrac Cadet EWT 1000 4WD
0446 225 882	Versotrac Cadet Control unit

The Versotrac Cadet Control unit is delivered with the following two items:

0460 820 983	EAC 10 control pendant
0445 680 882	Versotrac Cadet Control box

Spare parts may be ordered through your nearest ESAB dealer, see [esab.com](https://www.esab.com). When ordering, please state product type, serial number, denominations and ordering numbers according to the spare parts list. This facilitates dispatch and ensures correct delivery.

Maintenance and repair work should be performed by an experienced person, and electrical work only by a trained electrician. Use only recommended spare parts.

TABLE OF CONTENTS

---

<b>1</b>	<b>SPARE PARTS</b> .....	<b>4</b>
1.1	Tractor base .....	4
1.2	Tractor boom.....	6
	1.2.1 Wire straightener .....	9
1.3	Pillar.....	10
1.4	Versotrac Cadet Control unit.....	13
	1.4.1 Versotrac Cadet Control Box .....	13
	1.4.2 Harness list.....	16
	1.4.3 EAC 10 control pendant .....	18

# 1 SPARE PARTS

## 1.1 Tractor base

Item	Qty	Ordering no.	Denomination	Notes
1	2	0904 540 880	Guide bar	
2	1	0905 437 881	Foot clamp complete	
3	1	0904 252 880	Back cover complete	
4	1	0904 254 880	Front cover complete	
5	1	0904 524 880	Foot cover complete	
6	1		Frame	
7	1	0904 269 001	Isolation plate	
8	2	0190 726 002	Ball bearing	SKF 6002-2RS
9	4		Adjuster	Size 30-M8×20. Part of item 101
10	1	0904 528 880	Drive motor with connector	
11	2	0904 253 001	Cable support	
12	4		Roll pin	D5×28. Part of item 102
13	1	0904 297 001	Wheel shaft	
14	2	0904 290 001	Bearing housing	
15	4		Label	Yellow round. Part of item 101
16	2		Insulation	Versotrac. Part of item 101
17	4		High temp wheel	Versotrac. Part of item 102
18	4		Insulation cap	Versotrac. Part of item 101
19	1	0910 816 001	Plate	
20	4		Screw	MFT-TT M5×12
21	4		Screw	MC6S M6×16
22	4		Screw	MC6S M8×16
23	8		Nut	M8 Lock nut
24	4		Screw	M4×8 STL, FZB. Part of item 101
25	2		Lock ring	SGA 15
26	4		Screw	M6S M8×70
27	6		Screw	Ground cutter M5×10
28	1	0218 811 004	Ball grip	
29	1	0464 749 001	Direction indicator decal	
30	6		Screw	M5×10 STL, FZB
31	1	0904 274 880	Drive unit cable harness	

Spare parts sets

Item	Qty.	Ordering no.	Denomination	Notes
101	1	0464 666 010	Adjuster kit	Includes item 9, 15, 16, 18 and 24
102	1	0464 666 011	Wheel kit	Includes item 12 and 17
103	1	0910 053 880	4 Wheel drive kit	Included on 0910 944 881

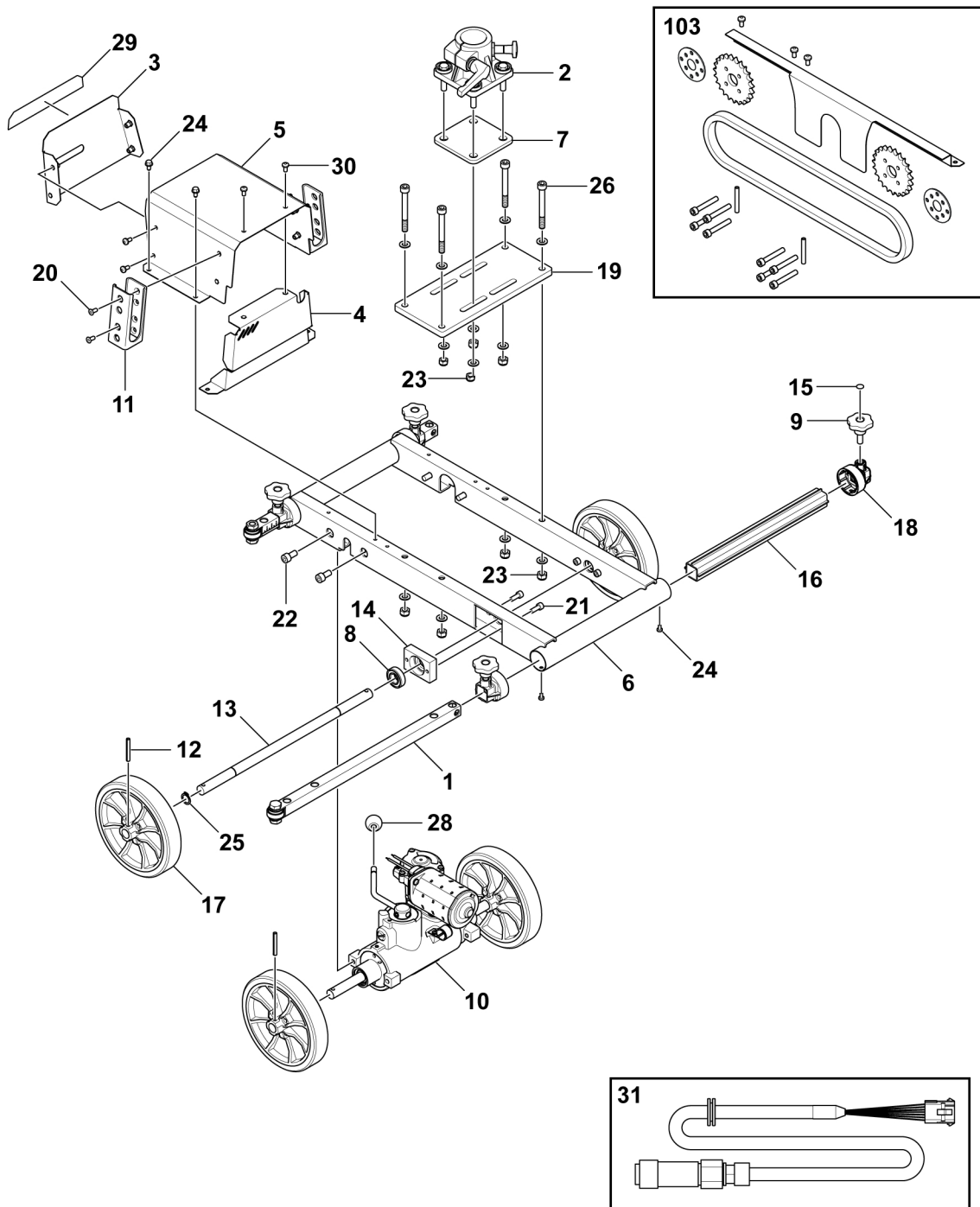

## 1.2 Tractor boom

Item	Qty	Ordering no.	Denomination	Notes
1	2	0413 518 880	Slide	90 mm, travel A2
2	1	0218 810 183	Insulated hand wheel	A2/A6
3	1	0334 571 880	Torch Clamp	A2 M8
4	1	0413 072 881	Bearing housing	A2 TFD/TGD
5	1	0416 984 880	Guide pin complete	A2TFD1
6	1	0905 429 882	Clamp	Cadet
7	1	0904 440 880	Wire straightener with memory	See " <a href="#">Wire straightener</a> ", page 9.
8	1	0905 177 001	Cover	A4
9	1	0332 994 883	Flux hopper	A2 TFD1
10	1	0413 318 001	Holder	A2 TFD1
11	1	0332 408 001	Stub shaft	A6
12	1	0413 510 001	Contact tube	D20, L=260 mm, A2 TFD1
13	1	0267 100 803	Cable gland	MKB
14	1	0910 826 001	Bracket	
15	1	0910 947 001	Bracket	
16	2	0910 865 001	Bracket	
17	2	0904 262 001	Linear scale	±4 cm
18	3	0910 873 001	Spacer plate	
19	1	0904 867 001	Rotational scale	±50
21	1	0904 703 001	Link	
22	1	0193 570 115	Locking arm	300 M6×16×63
23	1	0332 948 001	Flux delivery tube	A2 MINITR.
24	1	0443 383 001	Flux feeding hose	D32/25 poly
25	1	0905 724 001	Nipple	
26	1	0191 956 109	Hose plastics connection	
27	1	0153 148 880	Roller	A6 straightener
28	2		Screw	M10×30
29	4		Screw	M8×16 STL 8.8F
30	2		Screw	M8×30
31	4		Washer	D16/8.4
33	1		Screw	M6×30
34	4		Belleville washer	16/8.2
35	1		Washer	D22/10.5×22 STL HB-20
36	1		Washer	D12/6.4×1.5
37	3		Washer	M12
38	1		Nut	M10

1 SPARE PARTS

Item	Qty	Ordering no.	Denomination	Notes
39	1	0910 974 001	Motor	KSV 4030-801
40	1	0333 094 880	Clamp	A2 flux tube
41	1	0910 029 001	Alu-profile	40×40
42	4	0910 979 003	T-slot nut	M8, heavy duty
43	4	0910 979 002	T-slot nut	M6, heavy duty
44	4	0910 979 001	T-slot nut	M5, heavy duty
45	2	0904 215 001	Label	ESAB, 87.5 mm
46	2	0911 250 001	Plastic end cap	
47	2	0446 070 001	Warning sticker	
48	2		Screw	M8×16
49	2		Screw	M8×12 STL 8.8 F
50	4		Screw	M6×100
51	2		Screw	M6×16
52	8		Screw	M6×16 STL 8.8 F
53	4		Nut	M6
54	1		Pass screw	H10×16 M8
55	1	0449 475 001	Bar	A2
56	1		Screw	M10×30 STL 8.8 F
57	2		Washer	10.5×22 STL HB-20
58	2		Washer	D16/5×1
59	2		Screw	M5×12
60	2	0910 033 001	Enc cap	Versotrac
061	1	0911 257 001	Cable protection	

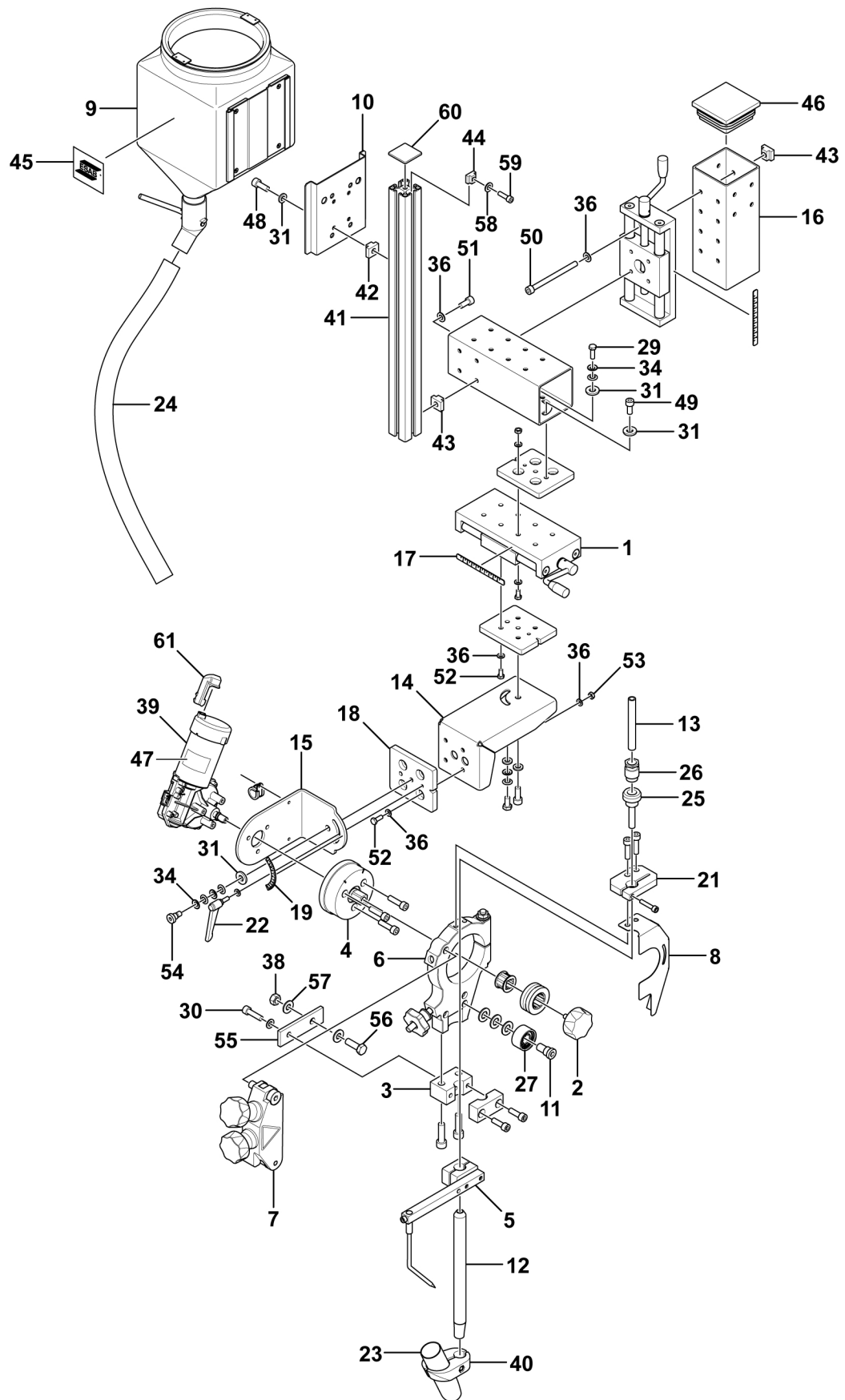

## 1.2.1 Wire straightener

Item	Qty.	Ordering no.	Denomination	Notes
		<b>0904 440 880</b>	<b>Wire straightener with memory</b>	
1	1		Pressure arm	
2	1		Hood	
3	1		Hood	
4	1		Shaft	
5	1		Stop screw	M4×8
6	2	0153 148 880	Roller	
7	1		Pass screw	H16×30
8	2	0332 408 001	Stub shaft	
9	1		Pass screw	H10×16-M8
10	1	0218 810 181	Insulated hand wheel	
11	1	0218 810 182	Insulated hand wheel	
12	1		Warning symbol	
13	1		Washer	12×18

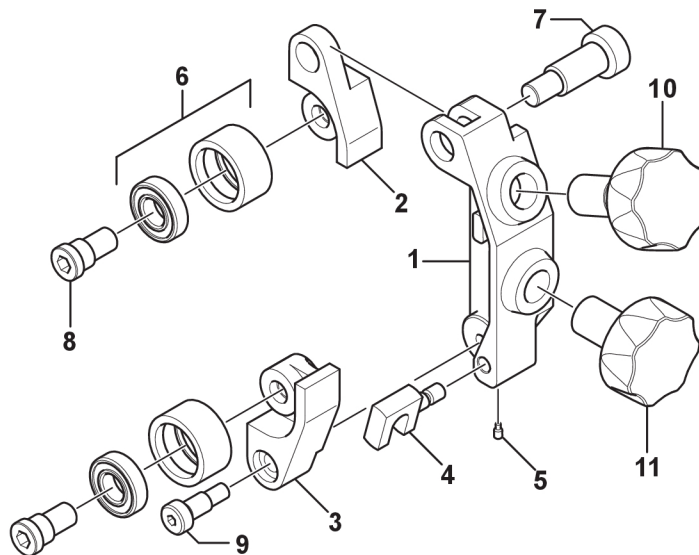

### 1.3 Pillar

Item	Qty	Ordering no.	Denomination	Notes
1	1		Versotrac Control Unit box	See " <i>Versotrac Cadet Control Box</i> ", page 13.
2	1	0910 686 880	Foot	
3	1	0146 967 880	Brake hub	A9 A10
4	1	0460 964 001	Bracket	Aristo U <sub>82</sub>
5	1	0906 066 001	Bobbin cover	
7	1	0910 890 001	Bracket	
8	1	0910 869 001	Bracket for electrical cabinet	
9	4		Screw	M6CS M8×30, part of Handle kit
10	1		Nut	M12 Lock nut
11	4		Washer	BRB M8, part of Handle kit
12	1		Screw	M6CS M8×30
13	1		Eye bolt	LT 12, part of Handle kit
14	1	0911 018 001	Aluminium profile	80×80×495
15	8	0910 979 003	T-slot nut	M8, Heavy duty
16	4	0910 979 002	T-slot nut	M6, Heavy duty
17	2	0910 975 001	Angle bracket	
18	1		Handle	Versotrac cadet, part of Handle kit
19	1		Setting box	EAC 10
21	1	0413 366 114	Clamp	57×42×30 D30
22	1	0464 748 001	Logo decal	Versotrac cadet
23	2		Tube plug	Part of Handle kit
24	1	0417 699 005	Clamp Rubber/Steel	EWH 1000 Versotrac
25	1		Nut	Nylon lock, part of Handle kit
26	2		Screw	M6×50
27	2		Nut	M6
28	2		Washer	6.4×11
30	4		Screw	M8×20
31	4		Washer	D16/8.4×3
32	2		Screw	M8×16
33	2		Screw	M8×25
34	2		Nut	M8
35	2		Screw	M6×20 H
36	2		Washer	D12/6.4×1.5
37	2		Nut	M6 STL D80
38	4		Screw	M5×16
39	2		Nut	Heavy duty T-slot M5

1 SPARE PARTS

Item	Qty	Ordering no.	Denomination	Notes
40	4		Washer	D10/5.3×1
41	2		Nut	M6MF-8
42	1		Screw	M5×16
43	1	0911 253 001	Washer	
44	1		Washer	D30/17×3
45	1		Nut	M16

**Spare parts sets**

Item	Qty.	Ordering no.	Denomination	Notes
1	1	0464 666 020	Handle kit	Includes item 9, 11, 13, 18, 23 and 25

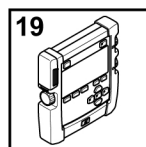
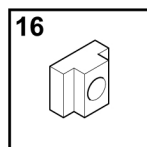
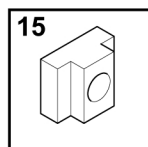
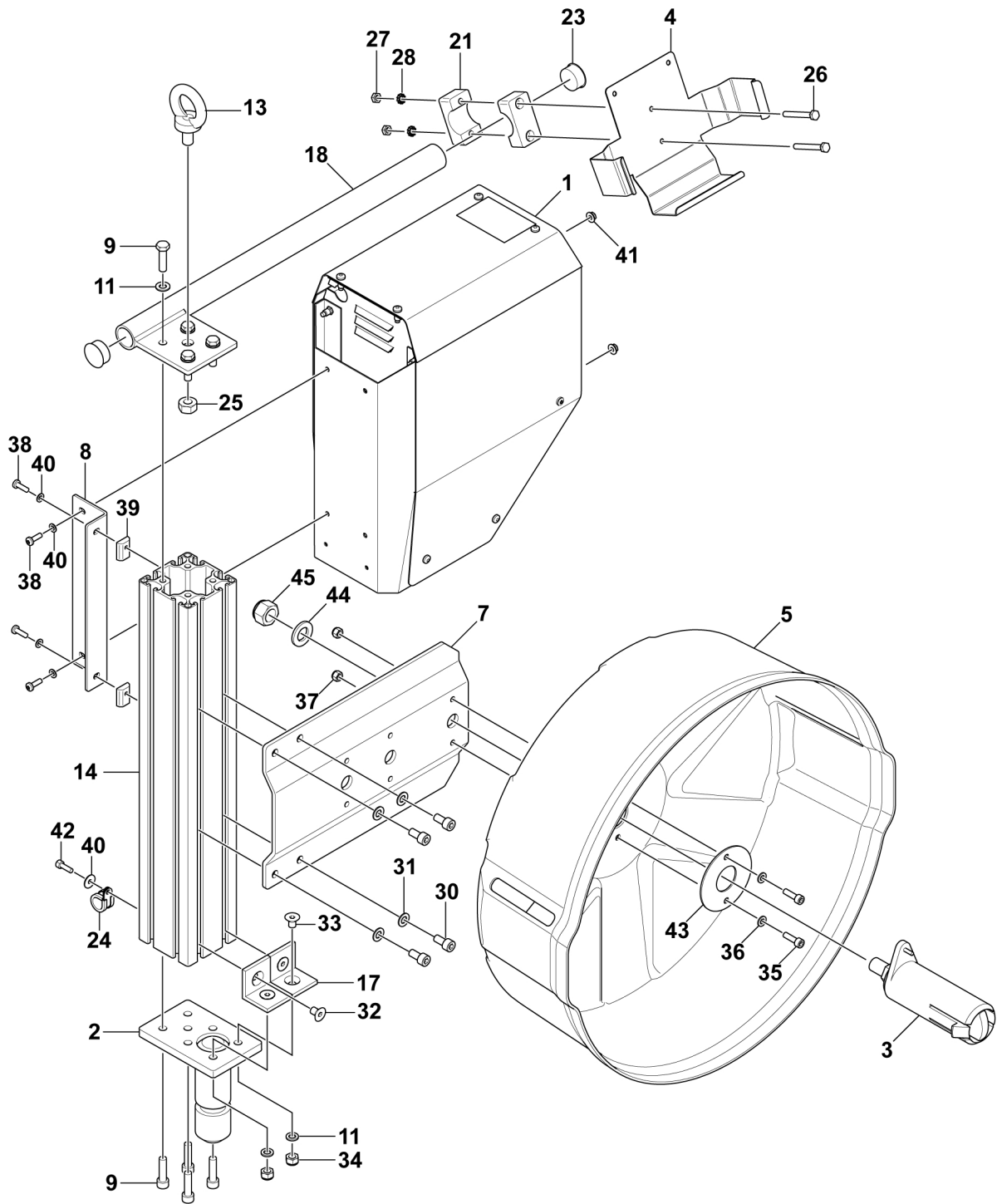

## 1.4 Versotrac Cadet Control unit

### 1.4.1 Versotrac Cadet Control Box

Item	Qty.	Ordering no.	Denomination	Notes	C
1	1	0445 695 880	Rear plate assembly		
2	1	0445 743 001	Right side panel		
3	1	0445 742 001	Left side panel		
4	1	0445 676 001	Top cover		
5	1	0445 682 880	Intermediate assembly		
6	1		Front plate assembly	Part of Front plate kit	
7	1	0445 696 880	Mounting bracket assembly		
8	1	0445 733 001	Thermal insulation sheet		
10	1	0487 522 785	Motor control board		26AP1
11	1	0487 528 882	Motor drive board		26AP2
12	1	0445 684 001	Heat sink		
13	1	0465 965 001	On/Off switch	Including knob	S1
14	1	0523 300 201	Work piece voltage feedback connector	Pin plug 4 mm 1-pol	XP5
15	6	0194 292 020	Grommet	D20	
16	1	0193 316 208	Rectifier bridge		BR1
17	00.1		Heat conductive paste	Wacker Silicone Paste P12	
18	1		DIN rail		
19	1	0194 344 024	Terminal block	Male 24-pole	X1
20	1	0194 345 024	Terminal block	Female 24-pole	X1
21	1	0460 652 001	Decal terminal		
22	1	0466 884 003	Connection block (virtual ground)		VG
23	18		Screw	M5×12	
24	4		Screw	M5×6	
25	13		Screw	ST3.5×9.5	
26	4		Plain washer	5-200 HV-A2K	
27	2		Cup spring	M5A-12, 5-1	
28	2		Screw	M4×12	
29	8		Screw	M4×8	
30	5	0460 859 002	Spacer screw	Ø 8/4.3 L=5	
31	9		Distance screw	M4×30	
33	7		Nut	M4	
34	1	0192 790 109	Spacer	28.6 mm	
35	2		Screw	M4×16	
36	1		Connector decal	Part of Front plate kit	

1 SPARE PARTS

Item	Qty.	Ordering no.	Denomination	Notes	C
37	1	0193 700 703	Ribbon cable with connectors		
38	1	0445 202 880	Varistor with connectors		
57	1		Rating plate		
58	1		Tape	56 mm, L=100 mm	
59	1		Screw	M5×12	
60	4		Screw	M3×8	
61	4		Nut	M3	

**Spare parts sets**

Item	Qty.	Ordering no.	Denomination	Notes
1	1	0464 666 104	Front plate kit	Includes item 6 and 36

1 SPARE PARTS

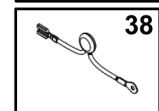
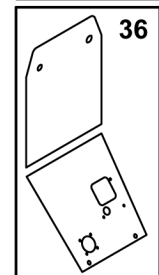
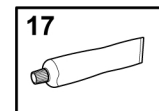
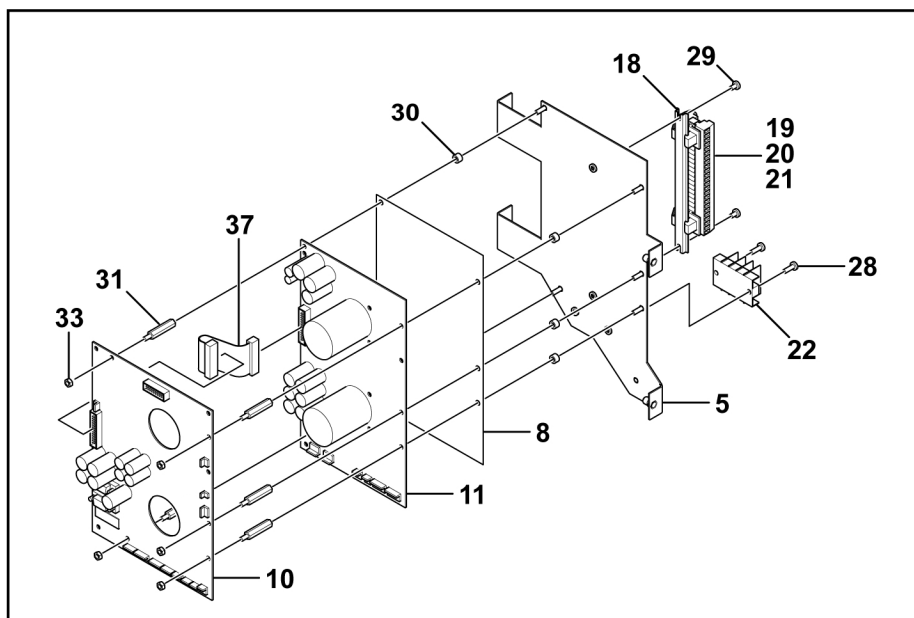
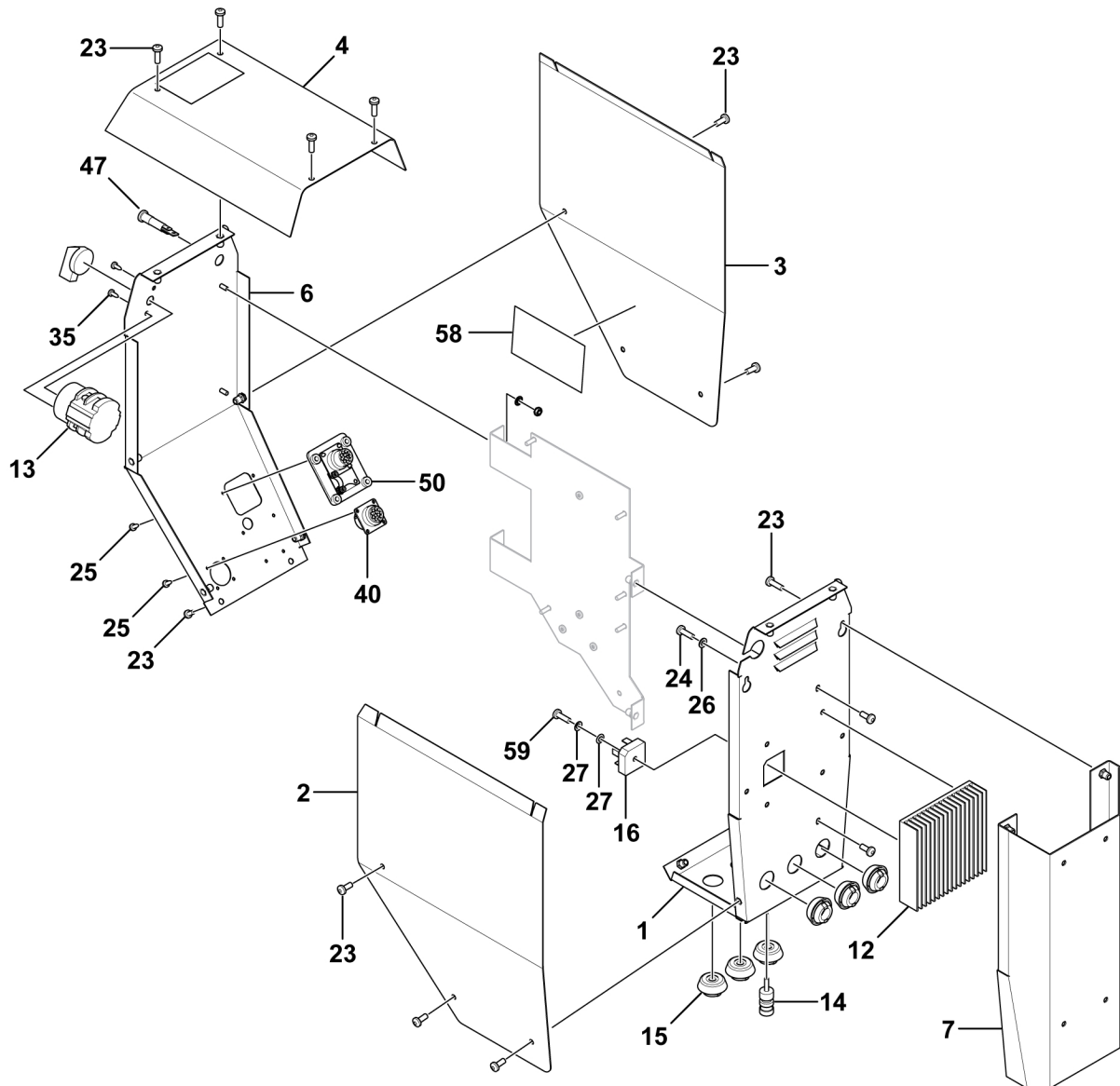

## 1.4.2 Harness list

Item	Qty.	Ordering no.	Denomination	Notes	C
39	1	0910 971 880	Motor cable	Cadet	
40	1	0445 553 880	Motor harness	Includes XP3	
41	1	0445 147 880	Relay harness I		
42	1	0445 551 880	Relay harness II		
43	1	0445 556 880	Limit switch harness		
44	1	0445 887 880	On/Off switch harness		
45	1	0445 888 880	ArcV minus cable		
46	1	0445 889 880	Rectifier AC harness		
47	1	0445 890 880	On/Off indicator harness	Includes HL1	
48	1	0910 978 880	Rectifier DC harness	Cadet	
49	1	0445 893 880	Laser lamp harness	Optional	
50	1	0445 892 880	CAN power source harness	Includes XP1	
51	1	0910 973 880	Arc volt cable	Cadet	
52	1	0910 972 880	Encoder cable	Cadet	
53	1	0910 977 880	Welding head detection cable	Includes XP2	
54	1	0445 606 880	A/D VG harness		
55	1	0445 608 880	Jumper harness		
56	1	0445 529 880	CAN power harness		

1 SPARE PARTS

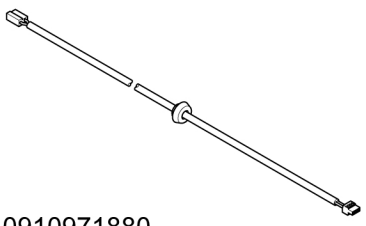
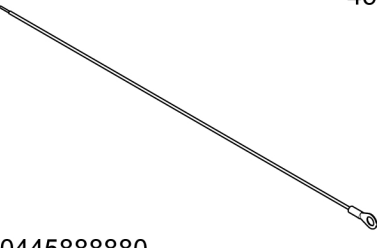
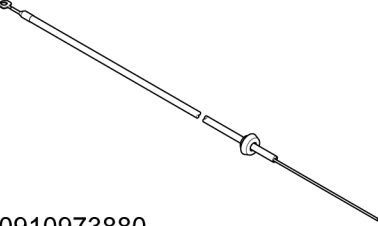
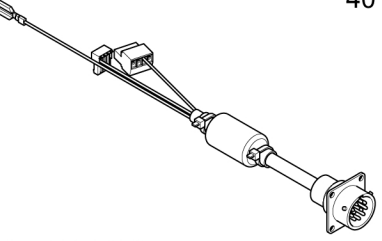
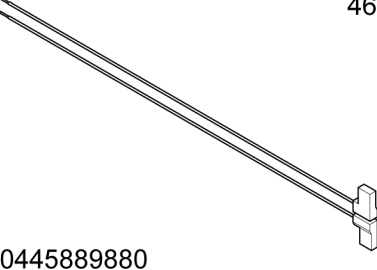
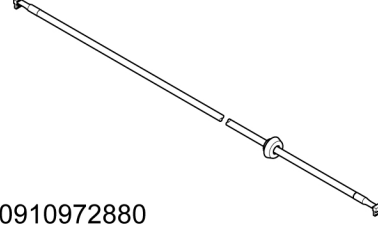
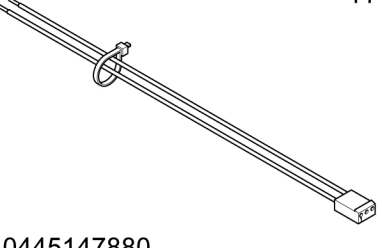
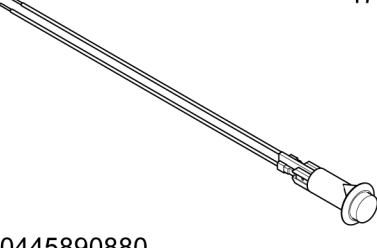
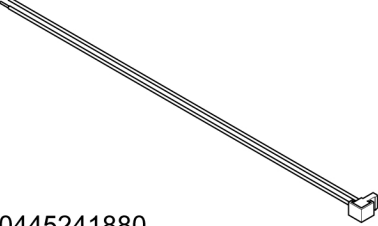
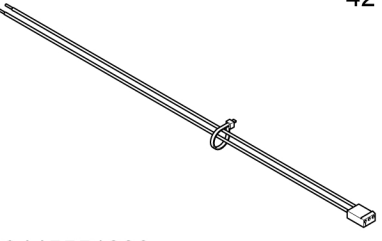
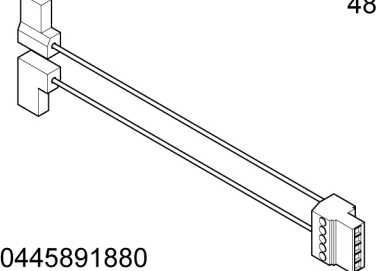
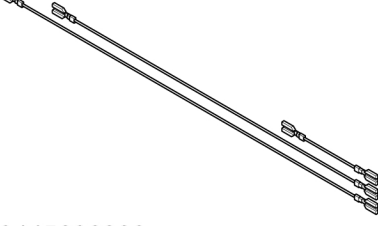
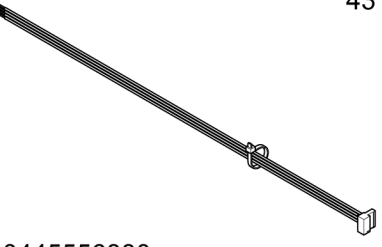
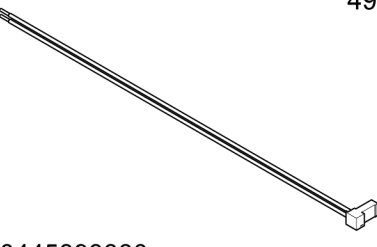
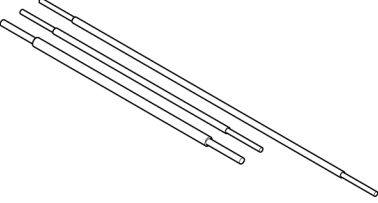
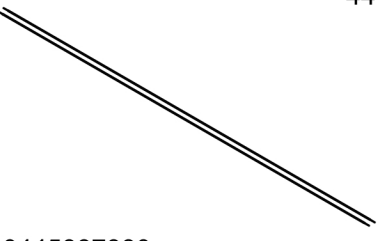
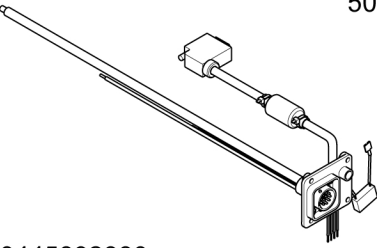
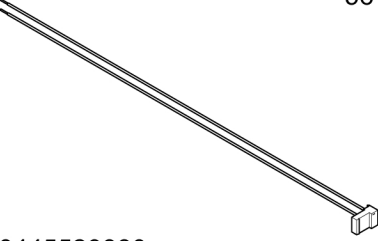
<p>39</p>  <p>0910971880</p>	<p>45</p>  <p>0445888880</p>	<p>51</p>  <p>0910973880</p>
<p>40</p>  <p>0445553880</p>	<p>46</p>  <p>0445889880</p>	<p>52</p>  <p>0910972880</p>
<p>41</p>  <p>0445147880</p>	<p>47</p>  <p>0445890880</p>	<p>53</p>  <p>0445241880</p>
<p>42</p>  <p>0445551880</p>	<p>48</p>  <p>0445891880</p>	<p>54</p>  <p>0445606880</p>
<p>43</p>  <p>0445556880</p>	<p>49</p>  <p>0445893880</p>	<p>55</p>  <p>0445608880</p>
<p>44</p>  <p>0445887880</p>	<p>50</p>  <p>0445892880</p>	<p>56</p>  <p>0445529880</p>

### 1.4.3 EAC 10 control pendant

Item	Qty.	Ordering no.	Denomination	Notes	C
1	1		Plastic box	Part of Pendant box kit	
4	1	0460 823 001	Rubber piece right		
5	1	0460 824 001	Rubber piece left		
6	1	0487 608 886	Welding data board		1AP1
7	1	0487 696 880	USB board		1AP4
8	1	0460 918 880	Cable harness		
9	1	0445 804 880	Membrane panel		1AP3
10	1	0193 949 003	Display		1AP2
11	3	0460 828 001	Knob		
12	1	0445 886 880	Pendant cable harness		
13	1		Sticker ESAB	Part of Pendant box kit	
14	16		Screw	Reform torx 4×12	
15	3	0193 912 002	Pulse encoder		
16	1	0460 850 001	Cover rubber		
17	1	0460 852 001	Shield plate		
20	2		Rubber foot	Part of Pendant box kit	
21	1		Magnet holder	Part of Pendant box kit	
22	1		Battery	CR2450, 3 V	
23	1		Fitting for box		

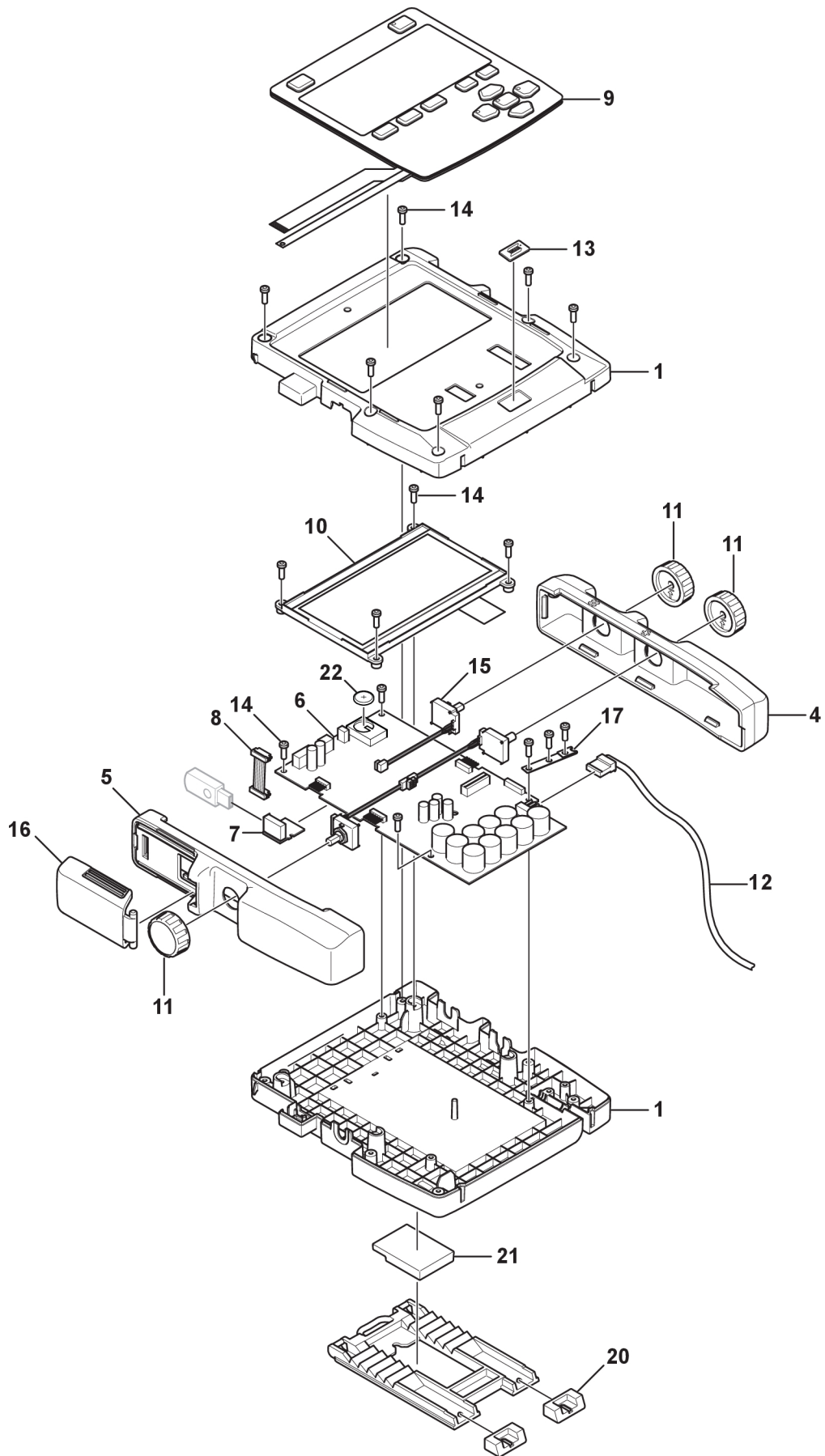



# A WORLD OF PRODUCTS AND SOLUTIONS.



For contact information visit [esab.com](http://esab.com)

ESAB AB, Lindholmsallén 9, Box 8004, 402 77 Gothenburg, Sweden, Phone +46 (0) 31 50 90 00

[manuals.esab.com](http://manuals.esab.com)

